SFP-10G-LR-OC
1310nm SFP+ single-Mode for 8G FC / 10 GbE
Duplex SFP+ Transceiver
RoHS 6 Compliant



Features

- ◆ Operating data rate up to 10.3Gbps
- ◆ 1310nm DFB-LD Transmitter
- ◆ Distance up to 10km
- ◆ Single 3.3V Power supply and TTL Logic Interface
- ◆ Duplex LC Connector Interface
- ◆ Hot Pluggable
- ◆ Operating Case Temperature
Standard: 0°C~+70°C
- ◆ Compliant with MSA SFP+ Specification SFF-8431
- ◆ Compliant with IEEE 802.3ae 10GBASE-LR
- ◆ Compliant with IEEE 802.3ae 10GBASE-LW
- ◆ Compliant with SFF-8472 MSA Digital diagnostic monitor interface

Applications

- ◆ 1X2X4X8 Fiber Channel
- ◆ 10GBASE-LR at 10.31Gbps
- ◆ 10GBASE-LW at 9.95Gbps
- ◆ Other optical links

Ordering information

Part No.	Data Rate	Laser	Fiber Type	Distance	Optical	DDMI
----------	-----------	-------	------------	----------	---------	------

					Interface	
SFP-10G-LR-OC	10.3Gbps	1310nm DFB	SMF	10km	LC	YES

Regulatory Compliance

Feature	Standard	Performance
Electrostatic Discharge (ESD) to the Electrical Pins	MIL-STD-883G Method 3015.7	Class 1C (>1000 V)
Electrostatic Discharge to the enclosure	EN 55024:1998+A1+A2 IEC-61000-4-2 GR-1089-CORE	Compliant with standards
Electromagnetic Interference (EMI)	FCC Part 15 Class B EN55022:2006 CISPR 22B :2006 VCCI Class B	Compliant with standards Noise frequency range: 30 MHz to 6 GHz. Good system EMI design practice required to achieve Class B margins. System margins depend on customer host board and chassis design.
Immunity	EN 55024:1998+A1+A2 IEC 61000-4-3	Compliant with standards. 1kHz sine-wave, 80% AM, from 80 MHz to 1 GHz. No effect on transmitter/receiver performance is detectable between these limits.
Laser Eye Safety	FDA 21CFR 1040.10 and 1040.11 EN (IEC) 60825-1:2007 EN (IEC) 60825-2:2004+A1	CDRH compliant and Class I Laser product. TüV Certificate No. 50135086
Component Recognition	UL and CUL EN60950-1:2006	UL file E317337 TüV Certificate No. 50135086 (CB scheme)
RoHS6	2002/95/EC 4.1&4.2 2005/747/EC 5&7&13	Compliant with standards

Note: In light of item 5 in RoHS exemption list of RoHS Directive 2002/95/EC, Item 5: Lead in glass of cathode ray tubes, electronic components and fluorescent tubes.

In light of item 13 in RoHS exemption list of RoHS Directive 2005/747/EC, Item 13: Lead and cadmium in optical and filter glass. The three exemptions are being concerned for these transceivers, because these transceivers use glass, which may contain Pb, for components such as lenses, windows, isolators, and other electronic components.

Product Description

The SFP+LRseries single mode transceiver is a small form factor pluggable module for serial optical data communications such as 1X2X4X8 Fiber Channel, IEEE 802.3ae 10GBASE-LR/LW. It is with the SFP+ 20-pin connector to allow hot plug capability.

This module is designed for single mode fiber and operates at a nominal wavelength of 1310 nm. The transmitter section uses a 1310nm multiple quantum well DFB laser and is Class 1 Laser compliant according to International Safety Standard IEC-60825.

The receiver section uses an integrated InGaAs detector preamplifier (IDP) mounted in an optical header and a limiting post-amplifier IC.

Absolute Maximum Ratings

Parameter	Symbol	Min.	Max.	Unit
Storage Temperature	T _S	-40	+85	°C
Supply Voltage	V _{CC}	-0.5	3.6	V

Recommended Operating Conditions

Parameter	Symbol	Min.	Typical	Max.	Unit
Operating Case Temperature	T _A			+70	°C
Power Supply Voltage	V _{CC}	3.15	3.3	3.45	V
Power Supply Current	I _{CC}			300	mA
Surge Current	I _{Surge}			+30	mA
Baud Rate	10GBASE-LR		10.31		Gbps
	10GBASE-LW		9.95		
	8G FC		8.5		
	4G FC		4.25		
	2G FC		2.125		
	FC		1.063		

Performance Specifications - Electrical

Parameter	Symbol	Min.	Typ.	Max	Unit	Notes
Transmitter						
CML Inputs(Differential)	V _{in}	150		1200	mVpp	AC coupled inputs
Input Impedance (Differential)	Z _{in}	85	100	115	ohm	R _{in} > 100 kohms @ DC
Tx_DISABLE Input Voltage - High		2		3.45	V	

Tx_DISABLE Input Voltage - Low		0		0.8	V	
Tx_FAULT Output Voltage -- High		2		V _{CC} +0.3	V	I _o = 400µA; Host V _{CC}
Tx_FAULT Output Voltage -- Low		0		0.5	V	I _o = -4.0mA
Receiver						
CML Outputs (Differential)	V _{out}	350		700	mVpp	AC coupled outputs
Output Impedance (Differential)	Z _{out}	85	100	115	ohm	
Rx_LOS Output Voltage - High		2		V _{CC} +0.3	V	I _o = 400µA; Host V _{CC}
Rx_LOS Output Voltage - Low		0		0.8	V	I _o = -4.0mA
MOD_DEF (0:2)	VoH	2.5			V	With Serial ID
	VoL	0		0.5	V	

Performance Specifications - Optical

Parameter	Symbol	Min.	Typical	Max.	Unit
9µm Core Diameter SMF			10		km
Data Rate				10.3	Gbps
Transmitter					
Centre Wavelength	λ_c	1270	1310	1355	nm
Spectral Width (-20dB)	$\Delta\lambda$			1	nm
Average Output Power@10.3Gbps	P _{out}	-8		+0.5	dBm
Extinction Ratio@10.3Gbps	ER	3.5			dB
Average Power of OFF Transmitter	P _{off}			-30	dBm
Side Mode Suppression Ratio	SMSR	30			dB
Input Differential Impedance	Z _{IN}	90	100	110	Ω
TX Disable	Disable		2.0	V _{CC} +0.3	V
	Enable		0	0.8	
TX Fault	Fault		2.0	V _{CC} +0.3	V
	Normal		0	0.8	
TX Disable Assert Time	t _{off}			10	us
Receiver					
Centre Wavelength	λ	1260		1565	nm
Sensitivity@10.3Gbps	P _{min}			-14	dBm
Output Differential Impedance	Z _{OUT}	90	100	110	Ω
Receiver Overload	P _{max}	0.5			dBm
Optical Return Loss	ORL			-12	dB
LOS De-Assert	LOS _D			-15	dBm
LOS Assert	LOS _A	-25			dBm
LOS	High		2.0	V _{CC} +0.3	V

	Low		0		0.8	
--	-----	--	---	--	-----	--

SFP+ Transceiver Electrical Pad Layout

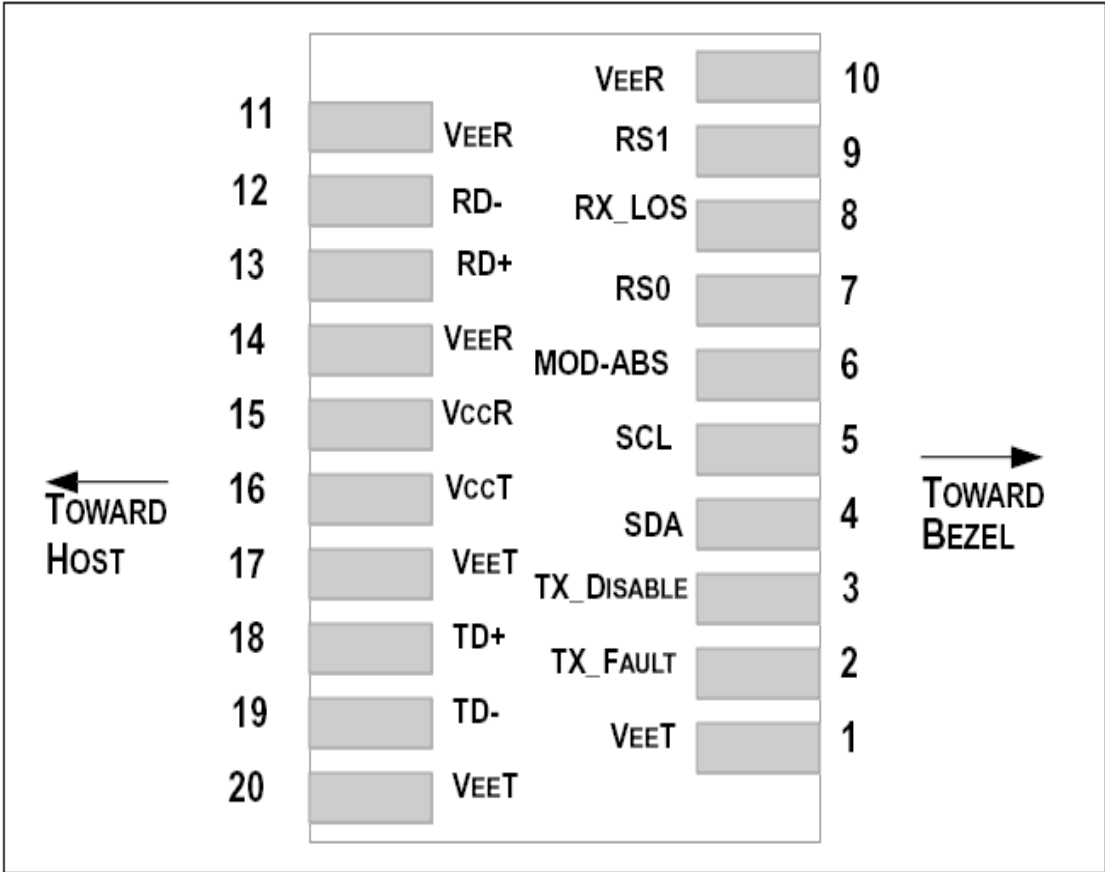

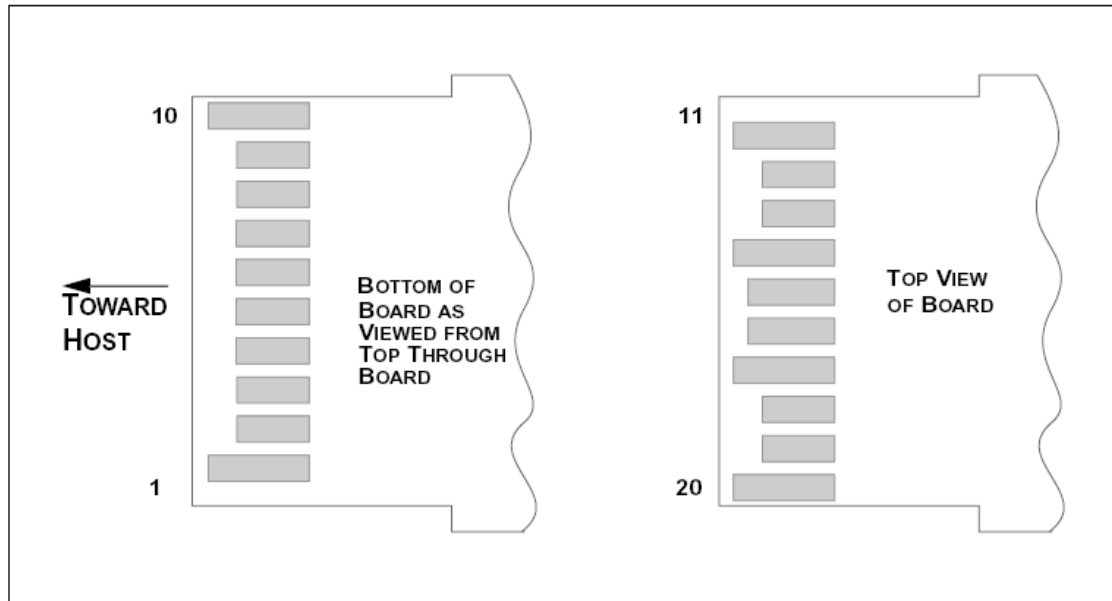

Pin Function Definitions

Pin Num.	Name	FUNCTION	Plug Seq.	Notes
1	VeeT	Transmitter Ground	1	Note 5
2	TX Fault	Transmitter Fault Indication	3	Note 1
3	TX Disable	Transmitter Disable	3	Note 2, Module disables on high or open
4	SDA	Module Definition 2	3	Note 3, Data line for Serial ID.
5	SCL	Module Definition 1	3	Note 3, Clock line for Serial ID.
6	MOD-ABS	Module Definition 0	3	Note 3
7	RS0	RX Rate Select (LVTTTL).	3	This pin has an internal 30k pull down to ground. A signal on this pin will not affect module performance.
8	LOS	Loss of Signal	3	Note 4
9	RS1	TX Rate Select (LVTTTL).	1	This pin has an internal 30k pull down to ground. A signal on this pin will not affect module performance.
10	VeeR	Receiver Ground	1	Note 5
11	VeeR	Receiver Ground	1	Note 5

12	RD-	Inv. Received Data Out	3	Note 6
13	RD+	Received Data Out	3	Note 7
14	VeeR	Receiver Ground	1	Note 5
15	VccR	Receiver Power	2	3.3 ± 5%, Note 7
16	VccT	Transmitter Power	2	3.3 ± 5%, Note 7
17	VeeT	Transmitter Ground	1	Note 5
18	TD+	Transmit Data In	3	Note 8
19	TD-	Inv. Transmit Data In	3	Note 8
20	VeeT	Transmitter Ground	1	Note 5

Notes:

1) TX Fault is an open collector/drain output, which should be pulled up with a 4.7K – 10KΩ resistor on the host board. Pull up voltage between 2.0V and VccT, R+0.3V. When high, output indicates a laser fault of some kind. Low indicates normal operation. In the low state, the output will be pulled to < 0.8V.

2) TX disable is an input that is used to shut down the transmitter optical output. It is pulled up within the module with a 4.7 – 10 KΩ resistor. Its states are:

Low (0 – 0.8V): Transmitter on

(>0.8, < 2.0V): Undefined

High (2.0 – 3.465V): Transmitter Disabled

Open: Transmitter Disabled

3) Modulation Absent, connected to VEET or VEER in the module.

4) LOS (Loss of Signal) is an open collector/drain output, which should be pulled up with a 4.7K – 10KΩ resistor. Pull up voltage between 2.0V and VccT, R+0.3V. When high, this output indicates the received optical power is below the worst-case receiver sensitivity (as defined by the standard in use). Low indicates normal operation. In the low state, the output will be pulled to < 0.8V.

5) VeeR and VeeT may be internally connected within the SFP+ module.

6) RD-/+ : These are the differential receiver outputs. They are AC coupled 100Ω differential lines which should be terminated with 100Ω (differential) at the user SERDES. The AC coupling is done inside the module and is thus not required on the host board.

7) VccR and VccT are the receiver and transmitter power supplies. They are defined as 3.3V ±5% at the SFP+ connector pin. Maximum supply current is 300mA. Recommended host board power supply filtering is shown below. Inductors with DC resistance of less than 1 ohm should be used in order to maintain the required voltage at the SFP+ input pin with 3.3V supply voltage. When the recommended supply-filtering network is used, hot plugging of the SFP+ transceiver module will result in an inrush current of no more than 30mA greater than the steady state value. VccR and VccT may be internally connected within the SFP+ transceiver module.

8) TD-/+ : These are the differential transmitter inputs. They are AC-coupled, differential lines with 100Ω differential termination inside the module. The AC coupling is done inside the module and is thus not required on the host board.

EEPROM

The serial interface uses the 2-wire serial CMOS EEPROM protocol defined for the ATMEL AT24C02/04 family of components. When the serial protocol is activated, the host generates the serial clock signal (SCL). The positive edge clocks data into those segments of the EEPROM that are not write protected within the SFP+ transceiver. The negative edge clocks data from the SFP+ transceiver. The serial data signal (SDA) is bi-directional for serial data transfer. The host uses SDA in conjunction with SCL to mark the start and end of serial protocol activation. The memories are organized as a series of 8-bit data words that can be addressed individually or sequentially.

The Module provides diagnostic information about the present operating conditions. The transceiver generates this diagnostic data by digitization of internal analog signals. Calibration and alarm/warning threshold data is written during device manufacture. Received power monitoring, transmitted power monitoring, bias current monitoring, supply voltage monitoring and temperature monitoring all are implemented. If the module is defined as external calibrated, the diagnostic data are raw A/D values and must be converted to real world units using calibration constants stored in EEPROM locations 56 – 95 at wire serial bus address A2h. The digital diagnostic memory map specific data field define as following .For detail EEPROM information, please refer to the related document of SFF 8472 Rev 10.2.

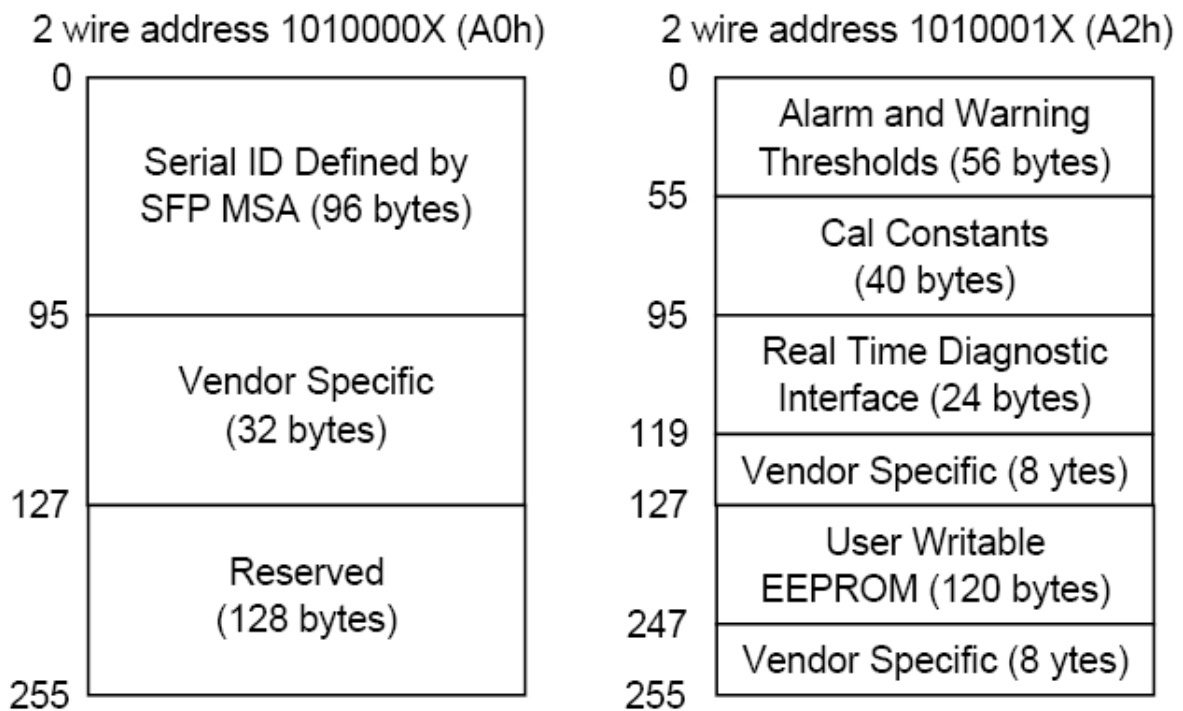

Recommend Circuit Schematic

Mechanical Specifications

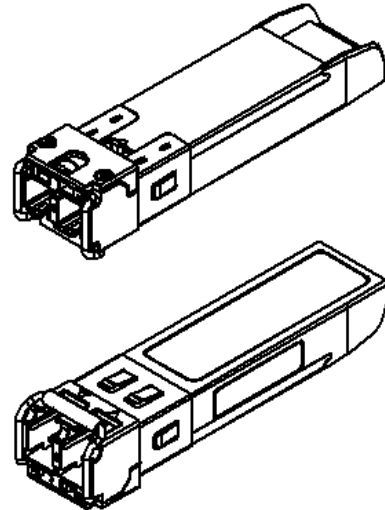
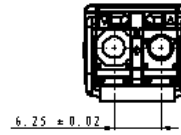
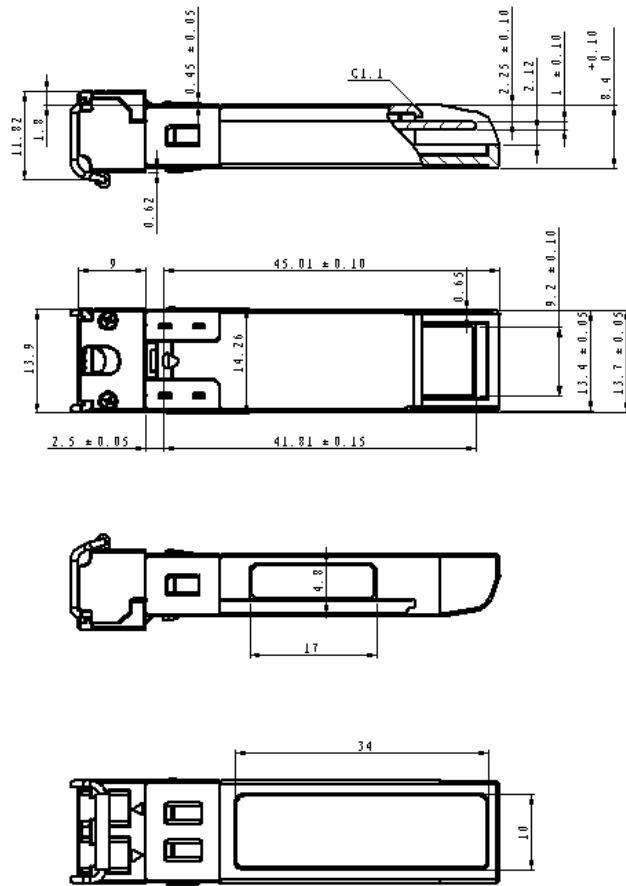

Eye Safety

This single-mode transceiver is a Class 1 Laser product. It complies with IEC-60825 and FDA 21 CFR 1040.10 and 1040.11. The transceiver must be operated within the specified temperature and voltage limits. The optical ports of the module shall be terminated with an optical connector or with a dust plug.